



## Building's Moving Procedures

*Please review the following moving procedures prior to the move in date:*

- Moves must occur before 7am or after 7pm weekdays, or anytime with advanced notice on the weekends.
- Tenant is responsible for supervising move and providing suite and building access.
- Floor and wall protection (i.e., Masonite) must be used to cover common area surfaces where items will be moved.
- Please notify Management 48 hours prior if you would like to request management to provide any access necessary.
- Loading Dock Information:
  - Building does not have a loading dock.
  - Parking can be found on Montgomery Street for afterhours moves.
- Elevator Information: See diagram on next page for freight elevator dimensions.

Russ Building  
235 Montgomery Street, Suite 1125  
San Francisco, CA 94104  
415-421-7424  
russbuilding@shorenstein.com

Car J (Freight Elevator)

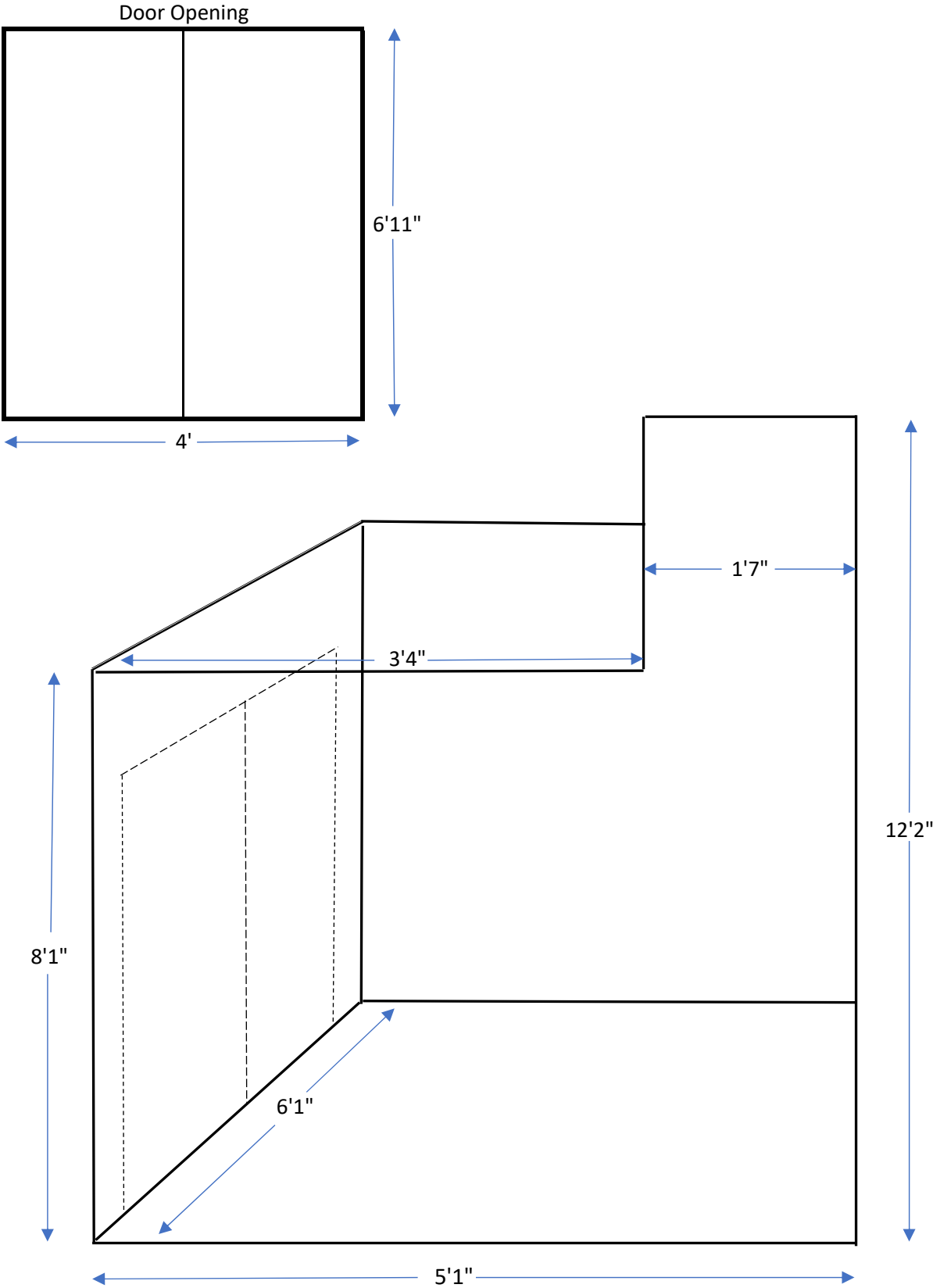

Sidewalk Freight Measurements

